

Outline Dimension

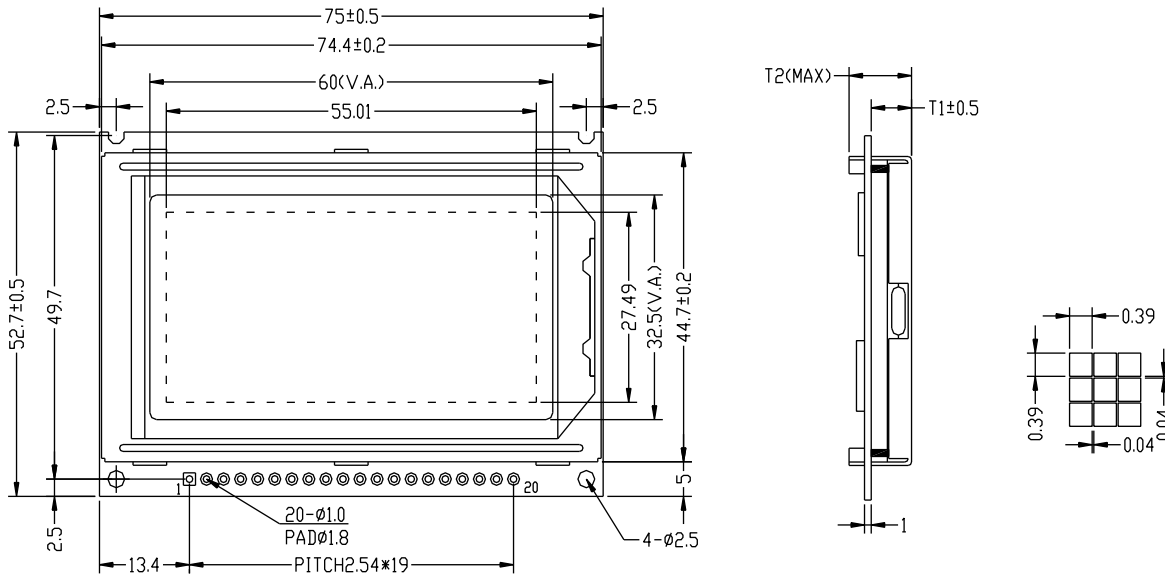

Block diagram

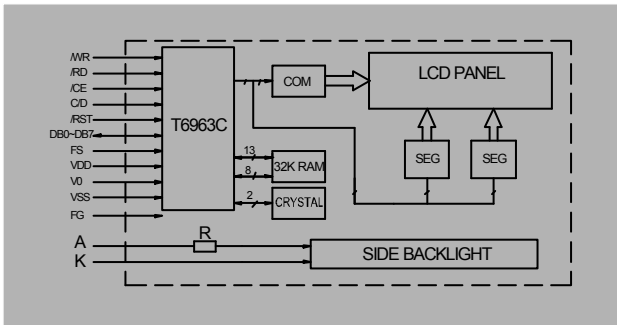

Feature

1. 128X64 dots graphic LCD module
2. Built-in controller (S6B0108)
3. 5.0V power supply
4. STN; 1/64 duty; LED BKL or EL BKL

Mechanical Data

Item	Standard	Unit
Module dimension	75.0x52.7	mm
Viewing area	60.0x32.5	mm
Dot size	0.39x0.39	mm
Dot pitch	0.43x0.43	mm

Absolute Maximum Rating

Item	Symbol	Standard			Unit
		Min	Typ	Max	
Power supply	VDD-VSS	-0.3	-----	7.0	V
Input voltage	VI	-0.3	-----	VDD+0.3	

Electronical characteristics

Item	Symbol	Condition	Standard			Unit
			Min	Typ	Max	
Input voltage	VDD	-----	4.5	5.0	5.5	V
		-----	-----	-----	-----	V
Supply current	I _{DD}	VDD=5V	-----	4.5	6.5	mA
Recommended LCD driving voltage for normal temp version module	VDD-V0	-20°C	-----	-----	-----	V
		0 °C	-----	9.8	-----	
		25°C	-----	9.5	-----	
		50°C	-----	9.3	-----	
LED forward voltage	VF	25°C	-----	4.2	4.6	V
LED forward current	IF	VF=4.2V	-----	250	-----	mA
EL power supply current	I _{EL}	V _{EL} =110V AC 400Hz	-----	-----	-----	mA

THICKNESS

VERSION	T1	T1	UNIT
EL&NO BACKLIGHT	6.2	10.0	mm
LED BACKLIGHT	8.8	12.5	